

Electronic Journal of Plant Breeding



Research Note

CoPb 14185: A midlate sugarcane variety for North West Zone of India

Vikrant Singh¹, Kuldeep Singh², R S Singh², Rajinder Pal³, Anuradha³ and Rajinder Kumar³

¹Punjab Agricultural University, Regional Research Station, Gurdaspur-143521, Punjab, India

²Punjab Agricultural University, Regional Research Station, Faridkot-151203, Punjab, India

³Punjab Agricultural University, Regional Research Station, Kapurthala-151203, Punjab, India

*E-Mail: vikrantsingh1986@pau.edu

Abstract

CoPb 14185 is a mid-late maturing sugarcane clone, selected from the polycross (PC) population of CoS 8436, at PAU Regional Research Station, Faridkot during 2008-09. CoPb 14185 was evaluated under AICRP(S) at nine locations in the North West Zone (NWZ) of India with two plant crops and one ratoon (2P+1R) during 2017-20. CCS (Commercial Cane Sugar) yield of CoPb 14185 in North West Zone (NWZ) was 11.58 t/ha with 11.10 and 3.86 per cent improvement than the best standard, Co 05011 and qualifying variety, CoS 14233, respectively. The cane yield of CoPb 14185 was 88.99 t/ha with 7.07 and 1.73 per cent higher than the best standard and qualifying variety, respectively. Pol% in cane of CoPb 14185 was 14.27, which was on par to the standards and qualifying variety. CoPb 14185, ranked first with 18.50% sucrose content (2P+1R), was observed more tolerant to prevalent diseases and insect-pests. It has erect medium thick whitish yellow green cylindrical cane (i.e. ~ 210.50 cm length, ~2.44 cm diameter), with pentagonal bud, curved leaf canopy, purple dewlap, incipient auricle and deltoid ligule. CoPb 14185 has been identified and released as a best mid-late variety through the Central Variety Release Committee (CVRC) for realizing higher cane yield and sugar recovery in NWZ of India.

Keyword: AICRP(S), CoPb 14185 (CoPb 98), CCS yield, CVRC, Sugarcane

Global sugarcane production is close to 1.80 billion tonnes (estimated during 2018-19), 1.75 billion tonnes (forecast during 2019-20) per annum; and is mainly concentrated in tropical regions particularly in developing nations like Latin America, Africa and Asia including predominantly India (FAO, 2019). In India, sugarcane ranks third after paddy and wheat by area wise. It is being cultivated in both tropical and sub-tropical regions of India in a 5.11 million ha area with 400.22 million tonnes of production and 78.30 t/ha productivity (Sugar statistics, 2020). Four major states i.e. Bihar, Haryana, Punjab and Uttar Pradesh under sub-tropical region are having 2.64 million ha sugarcane area with 206.72 million tonnes

of production and 73.68 t/ha productivity while seven major states i.e. Maharashtra, Gujarat, Andhra Pradesh, Karnataka, Tamil Nadu, Madhya Pradesh, Orissa under tropical region is having 2.23 million ha sugarcane area with 178.12 million tonnes production and 76.30 t/ha productivity (Sugar statistics, 2020). About 47 % of total sugarcane production in India comes from Uttar Pradesh (179.72 million tonnes), 24 % from Maharashtra (92.44 million tonnes), 11 % from Karnataka (42.01 mt), 4 % from Tamil Nadu (16.21 mt), 3 % from Bihar (11.66 mt), 2 % from Punjab (7.77 mt), 2 % from Haryana (7.57 mt) and so on. However, the subtropical state contributes 54 % of total cane production with 54 % area and 49 % productivity

while tropical state contributes 46 % production along with 46 % area and 51 % productivity (Sugar statistics, 2020).

The highest sugarcane productivity was reported for Tamil Nadu (98.24 t/ha) followed by Karnataka (83 t/ha), Uttar Pradesh (80.8 t/ha), Punjab (81.83 t/ha), Haryana (80.37 t/ha), Maharashtra (79.5 t/ha), Andhra Pradesh (79.33 t/ha), Gujarat (71.97 t/ha), Orissa (63.06 t/ha) and Bihar (58.95 t/ha) (Sugar statistics, 2020). Sugar recovery in India during the 2015-16 crushing season was 10.62 %. The highest recovery i.e. 11.33 % was reported in Maharashtra, followed by Telangana (10.85 %), Karnataka (10.74 %), Uttar Pradesh (10.61 %), Haryana (10.51 %), Punjab (10.06 %) and Gujarat (10.39 %). During the 2018-19 crushing season, sugar recovery of India was reported to be improved with 11.01 % (Sugar statistics, 2021); because of the changes in varietal scenarios and post-harvest management practices especially in Uttar Pradesh of subtropical India. These differences in state wise cane production, productivity and sugar recovery reveal the possibility of huge potential gain for increasing cane & sugar productivity through improved cultivar (Abuellail *et al.*, 2021; Saravanan *et al.*, 2021). Henceforth, it is a need to develop high yielding cultivars which could boost provincial as well as national cane sugar yields.

Varietal development progress appears to be satisfactory and may indicate the soundness of the employed breeding methods and techniques; if desired varieties are coming through it (Singh and Singh, 2021). Although modern breeding tools i.e. molecular breeding and transgenic transformation are available, classical methods still has the significant role in varietal development programmes (Anna Durai, 2015; Singh and Singh, 2021). In this situation, the biggest challenge for the breeders is to improve the selection strategies by reducing the time required for development of new cultivars. The exact answer to this problem is the "region specific breeding, evaluation and selection" of elite clones. So for this purpose, India has been divided into five agro-climatic zones (Anonymous, 2017a); and the identification of improved adapted genotypes for the concerned zones is in progress. All sugarcane breeding centres are concentrated in inbreeding varieties with the main objective to increase commercial cane sugar (CCS) content. Sugarcane research at Punjab Agricultural University (PAU) in the present study had led to the development of mid-late maturing varieties CoPb 14185 (CoPb 98) that can fulfil the above stated lacuna in the arena of Indian sugar industries.

CoPb 14185 (CoPb 98) was developed by clonal selection from the poly cross (PC) progenies of CoS 8436. The genealogy of developed clone CoPb 14185 is explained in **Fig. 1**. The parental clone "CoS 8436", was released by ICAR-Central Variety Release Committee, New Delhi under mid-late maturity group and, has been the ruling sugarcane variety under the North West Zone (NWZ)

of India since the variety has high sugar potential and has very responsive to fertilizers and irrigation without lodging. The crosses were attempted during November 2008-09 at National Hybridization Garden (NHG), ICAR-Sugarcane Breeding Institute, Coimbatore (Tropical region of India, Peninsular Zone, 11°00'58"N/76°58'16"E). Seedlings were raised under controlled conditions (Poly House, by maintaining high temperature i.e. 35-40°C and high humidity i.e. ~80-85%) during March to July 2009-10; by following recommended agronomic practices (Anonymous, 2020a). Clones were evaluated from the C1 stage (2010-11) to advanced yield trials (2013-14) at Punjab Agricultural University, Regional Research Station, Faridkot (South Western Zone, 30°40'00"N/74°45'00"E), Punjab. Further, identified the best clone "F 450/10" was proposed and included with the name of "CoPb 14185" in Zonal Varietal Trials of AICRP(S) during October 2014-15 for its evaluation and identification to be released as a variety at National level of India for NWZ [Punjab, Haryana, Rajasthan, Uttar Pradesh (North and Western) and Uttarakhand] States.

The accepted clone "F 450/10" (CoPb 14185) was multiplied for one year i.e. 2015-16 at SBI-Regional Centre, Karnal to supply sufficient cane seed to all the nine evaluating centres of AICRP(S) in NWZ of India. CoPb 14185 was evaluated along with 12 entries (Co 14035, CoH 14261, CoH 14262, CoLk 14203, CoLk 14204, CoLk 14205, CoPb 14183, CoPb 14184, CoPb 14212, CoS 14231, CoS 14232, CoS 14233) against four standards (CoS 767, CoS 8436, CoPant 97222, Co 05011) in Initial Varietal Trials (IVT) during 2017-18. Based on cane yield, sugar yield as well as reactions to diseases and insect-pests, CoPb 14185 was selected along with six entries (Co 14035, CoH 14261, CoLk 14203, CoLk 14204, CoPb 14184, CoS 14233) for further evaluation against the three checks (CoS 767, CoPant 97222 and Co 05011) in three consecutive Advanced Varietal Trials (AVT-I Plant, AVT-II Plant & AVT Ratoon) during 2018-19 and 2019-20. The trial was laid out in a randomized block design (RBD) with three replications and a plot size of 8 rows x 6.0 meters row length x 0.90 meters row to row spacing. The recommended packages of practices were adopted for raising a good and healthy crop.

Data was recorded on agro-morphological characters i.e. germination % (Gm %, the number of buds germinated per plot × 100/ number of buds planted per plot) at 45 DAP (days after planting), the number of tillers (000/ ha, the number of tillers per plot × 10/ area of the plot in m²) at 120 DAP, the number of shoots (000/ ha, the number of shoots per plot × 10/ area of the plot in m²) at 240 DAP, the number of millable canes (000/ ha, the number of NMC per plot × 10/ area of the plot in m²) at 360 DAP, cane yield (t/ha, cane yield in kg per plot × 10/ area of the plot in m²) at 360 DAP, stalk length (cm) at 360 DAP, single cane weight (kg) at 360 DAP, cane diameter (cm) at 360 DAP. Agro-morphological data were recorded on a plot basis and expressed on a hectare

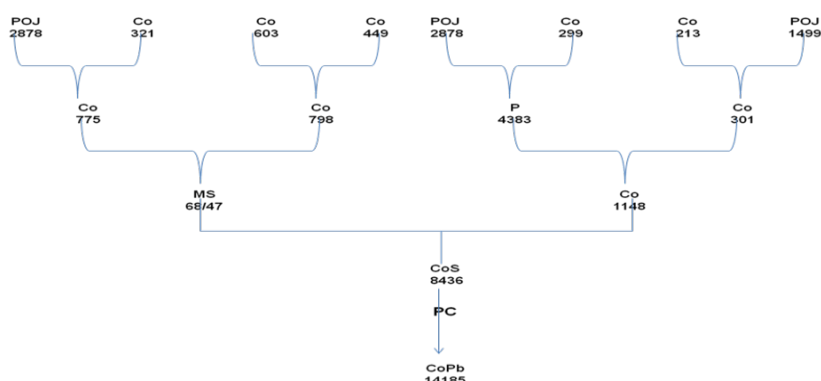

Fig. 1. Genealogy of sugarcane variety CoPb 14185 (CoPb 98)

basis. For juice quality parameters, brix (%), sucrose (%), purity (%) and commercial cane sugar (CCS %); data were taken twice i.e. at mid January and at mid March during the crop period and the standard protocol was followed (Meade and Chen, 1971). Commercial cane sugar (CCS) yield (t/ ha) was calculated as cane yield (t/ ha) x CCS% /100.

Test clones along with standards were evaluated for resistance against red rot, smut and wilt diseases under artificial conditions, while for resistance against pokkah boeng and yellow leaf diseases under natural conditions. Standard plug method and nodal cotton swab method were followed for testing clones against two pathotypes of red rot (*viz.*, CF08 from CoJ 84 and CF09 from CoS 767) during the last week of August (Srinivasan and Bhatt, 1961). Data were recorded on a 0-9 scale after 60 days of inoculations (Anonymous, 2017b). For smut resistance testing, three budded setts of each clone were inoculated by steeping of setts for 30 minutes in smut spores suspension of over 90 % viability and with a spore load of one million spores per milliliter before planting. Observations were made daily to record the manifestation of the first whip in test clones. Thereafter, smut counts were taken at fortnightly intervals up to harvesting of the crop, and the affected clumps were roughed out and destroyed to avoid secondary spread. Smut reaction was assessed based on total infected clumps (No. of affected clumps/total clumps × 100) and graded as resistant (0% - 10 % disease incidence), moderately resistant (0.1 % - 10 %), moderately susceptible (10.1 % - 20 %), susceptible (20.1 % - 30 %), highly susceptible (>30 %) (Anonymous, 2017b). Test clones for wilt symptoms were evaluated at the end of 10 months period with wilt severity index on a 0-4 scale as per the standard method of AICRP technical programme (Anonymous, 2017b). Natural incidence of pokkah boeng was recorded from June to September, and clones were graded as resistant (0 % - 5 % disease incidence),

moderately susceptible (>5 % - 10 %), susceptible (>10 % - 20 %), highly susceptible (>20 %). Natural incidence of YLD was also recorded by using the 0 - 5 grades scale as per prescribed under AICRP(S) technical programme during maturity stages of the crop (three observations by 8th, 10th and 12th months) (Anonymous, 2017b). Further, the incidences of sugarcane borer complex were recorded for early shoot borer, top borer and stalk borer as per the following formula:

Early shoot borer: The symptoms of early shoot borer are dead heart formation of the central shoot, and easily pulled out was observed during April to June months.

$$\text{Incidence of early shoot borer} = \frac{\text{Total number of dead heart shoots}}{\text{Total number of shoots}} \times 100$$

Top borer: The symptoms of top borer are shoot holes in the leaves and bunchy top is formed there. The per cent incidence was observed during the months of June, July and August.

$$\text{Incidence of top borer} = \frac{\text{Number of infested canes from 3 m row length}}{\text{Number of canes observed from 3 m row length}} \times 100$$

Stalk borer: The symptoms of stalk borer are the entrance and exit holes which was observed after cane stripping at harvest. Per cent incidence at harvest was recorded on 75 canes per replication.

$$\text{Incidence Stalk borer} = \frac{\text{Total number of affected canes}}{75 \text{ (Canes)}} \times 100$$

$$\text{Per cent intensity} = \frac{\text{Total number of affected internodes}}{\text{Total number of internodes}} \times 100$$

$$\text{Infestation index} = \frac{\text{Per cent incidence} \times \text{Per cent intensity}}{100}$$

Natural occurrences of diseases and insect pests in all the agronomical and crop improvement trials were also recorded.

Statistical analyses

All the recorded data pertaining to twelve different cane yield and juice quality traits were analysed (Snedecor and Cochran, 1967) using different software (SAS, SPSS, CPCS1, OPStat, SPAR 2.0) by different AICRP centres. The significance of variation among the treatments was compared by applying the 'F' test and critical difference (CD) at a 5% level of significance. The analysis of variance for each trait was based as per linear model (Panse and Sukhatme, 1978), and interpretations were made accordingly. The weighted mean of for different traits was calculated using the following formula:

$$\frac{(\text{Mean of AVT-I} \times \text{Number of trials}) + (\text{Mean of AVT-II} \times \text{Number of trials}) + (\text{Mean of Ratoon} \times \text{Number of trials})}{\text{Total Number of trials in AVT-I, AVT-II and Ratoon}}$$

RESULTS AND DISCUSSION

Analysis of variance (ANOVA) over years and locations across NWZ of India revealed significant differences among the clones (data given in PC Reports and PICI Reports of AICRP in IVT, AVT I Plant, AVT II Plant and AVT Ratoon trials for all traits (Anonymous, 2018; 2019; 2020) indicates the genetic differences among the testing clones for these traits and immense scope for their selection (Singh and Singh, 2021).

IVT was conducted during 2017-18 in NWZ at nine locations over five states (details given in the materials and methods section). CoPb 14185 recorded numerically higher cane yield and CCS yield over best standards viz., CoPant 97222 and Co 05011. Based on IVT performance for yield and quality, seven clones (details given in the materials and methods section) were selected (**Table 1**), and further evaluated in AVT Plant & Ratoon trials for identification and release as variety. In "AVT I Plant" trials conducted during 2018-19 (**Table 2**), CoPant 97222 was identified as the best standard for CCS yield across the zone which recorded 11.22 t/ha CCS yield. CoPb 14185 (12.77 t/ha,) showed 13.81 per cent improvement for the CCS yield (t/ha) over the best standard CoPant 97222. Entry CoPb 14185 recorded the highest zonal mean for cane yield 95.58 t/ha with 11.46 per cent improvement over the best standard CoPant

97222 (85.75 t/ha). CoPb 14185 (13.28% CCS and 19.15 % sucrose) recorded numerically superior CCS (%) and sucrose (%) as compared the best standard CoPant 97222 (Anonymous, 2019). During the year 2019-20 under "AVT II Plant" trials (**Table 2**), Co 05011 was the best standard and recorded the highest CCS yield of 10.90 t/ha. CoPb 14185 (12.72 t/ha) recorded the highest CCS yield with a 16.70 per cent improvement for CCS yield over the best standard Co 05011. Among the test clones, CoPb 14185 recorded the highest yield (97.91 t/ha) across the zone with a 10.13 per cent improvement over the best standard CoS 767 (88.90 t/ha). CoPb 14185 (13.00 %) recorded the numerically superior value for CCS (%) with a 3.11 per cent improvement over the best standard Co 05011. Test clone CoPb 14185 (18.67 %) recorded numerically superior values for sucrose content as compared to the best standard Co 05011 (18.12 %). During 2019-20 under "AVT Ratoon" trials in NWZ at nine locations (Table 2), Co 05011 was observed as the best standard and among the test clones, CoPb 14185 (12.56 %) recorded a 3.04 per cent improvement over Co 05011.

Pooled analyses of AVT I Plant, AVT II Plant and AVT Ratoon trials over nine locations and two seasons, the weighted mean CCS and cane yield, CCS % and sucrose % of CoPb 14185 along with standards are presented in **Table 2**. The mean CCS yield of the best standard, Co 05011 in the zone was 10.42 t/ha, while CoPb 14185 recorded a CCS yield of 11.58 t/ha an improvement of 11.11 per cent over Co 05011 in the zone, and recorded the highest performance among all testing clones and standards. For cane yield (t/ha), the best standard Co 05011 recorded 83.12 t/ha in the zone while CoPb 14185 recorded 88.99 t/ha cane yield with an improvement of 7.06 per cent over Co 05011 in the zone. CoPant 97222 was the best standard for CCS % with a zonal mean of 12.59 per cent, and CoPb 14185 (12.95 %) recorded numerically superior CCS (%) across the zone with 2.83 per cent improvement over the best standard. For sucrose per cent, CoPant 97222 was the best standard (18.12 %) while CoPb 14185 (18.50 %) recorded numerically superior sucrose content (%) across the zone with a 2.07 per cent improvement over the best standard in the zone. CoPb 14185 performed better than the other test clones and standards for juice quality as well.

Based on the ongoing research on sugarcane, a wide range for CCS (t/ha), cane yield, CCS %, sucrose % and other contributing traits have been well documented (Anonymous, 2018; 2019; 2020; Singh *et al.*, 2021) in the AICRP entries over years and locations. Breeding and selection for mid-late season sugar content in a sugarcane improvement program has been proposed by Cox *et al.* (1994); who selected elite late maturing clones with high CCS (%) and recycled them into the breeding population to generate desired clones. Charumathi and Naidu (2015) also performed a similar scientific concept for generating mid-late clone CoA 07322. Comparisons of cultivars released over years and locations indicate

Table 1. Summary data of Initial Varietal Trials conducted in North West Zone of India

S. No.	Entries	CCS t/ha	Cane yield t/ha	CCS%	Sucrose % at harvest
1	Co 14035	10.25	81.41	12.57	18.18
2	CoH 14261	10.71	82.50	13.04	18.76
3	CoLk 14203	11.11	90.43	12.30	17.93
4	CoLk 14204	10.52	82.43	12.79	18.53
5	CoPb 14184	10.85	89.42	12.14	17.61
6	CoPb 14185	11.19	88.81	12.61	18.17
7	CoS 14233	11.20	90.59	12.36	17.93
8	CoH 14262	9.70	77.74	12.49	18.01
9	CoLk 14205	10.73	85.20	12.53	18.04
10	CoPb 14183	11.11	90.37	12.50	17.94
11	CoPb 14212	10.42	83.85	12.46	17.97
12	CoS 14231	11.29	89.96	12.56	18.09
13	CoS 14232	11.93	96.35	12.38	17.80
Standards					
1	CoS 767	10.12	82.45	12.27	17.61
2	CoPant 97222	10.64	85.46	12.53	18.07
3	Co 05011	10.87	85.25	12.80	18.43
4	CoS 8436	9.68	76.43	12.70	18.12
Mean value over test clones		10.73	85.79	12.54	18.08

Table 2. Summary data of Advanced Varietal Trials conducted in North West Zone of India

Year of testing	Number of trials/ locations	CCS (t/ha) Zonal mean						Cane yield (t/ha) Zonal mean						Sucrose (%) Zonal mean			
		CoPb 14185	CoS 767	CoPant 97222	Co 05011	CoS 14233	CoPb 14185	CoS 767	CoPant 97222	Co 05011	CoS 14233	CoPb 14185	CoS 767	CoPant 97222	Co 05011	CoS 14233	
Plant-I (2018-19)	9	12.77	10.67	11.22	10.77	12.46	95.58	85.51	85.75	83.42	95.03	19.15	18.01	18.07	18.66	18.88	
Plant -II (2019-20)	9	12.72	10.63	10.38	10.90	12.43	97.91	88.90	83.10	86.83	97.22	18.67	17.74	18.83	18.12	18.20	
Ratoon (2019-20)	9	9.24	7.97	9.08	9.59	8.55	73.47	70.64	72.86	79.09	70.18	17.68	17.07	17.49	17.44	17.51	
Weighted Mean		11.58	9.76	10.23	10.42	11.15	88.99	81.68	80.57	83.11	87.48	18.50	17.61	18.13	18.07	18.20	
Percentage increase or decrease over the checks and qualifying varieties																	
Plant-I (2018-19)	9		19.68	13.81	18.57	2.49		11.78	11.46	14.58	0.58		6.33	5.98	2.63	1.43	
Plant -II (2019-20)	9		19.66	22.54	16.70	2.33		10.13	17.82	12.76	0.71		5.24	-0.85	3.04	2.58	
Ratoon (2019-20)	9		15.93	1.76	-3.65	8.07		4.01	0.84	-7.11	4.69		3.57	1.09	1.38	0.97	
Weighted mean			18.65	13.20	11.10	3.86		8.94	10.45	7.07	1.73		5.07	2.04	2.36	1.67	
Frequency in the top three group (pooled for three years)																	
	9+9+9	7+5+4	0+0+0	1+1+0	0+1+5	7+7+4	5+5+3	0+2+2	0+1+2	0+0+6	6+7+4	6+5+5	0+0+2	1+0+1	2+1+1	4+4+3	
	27	16/27	0/27	2/27	6/27	18/27	13/27	4/27	3/27	6/27	17/27	16/27	2/27	2/27	4/27	11/27	

Note: Qualifying variety is one which records either 10 % improvement for cane yield along with numerically superior for sucrose content or 5 % improvement for sucrose content along with numerically superior for cane yield as compared to best standard. (CoS 14233 was chosen as QV since it was only 2nd entry after CoPb 14185 in AVT -I & -II Plant trials along with it stood 2nd for CCS Yield).

Table 3. Adaptability to agronomic variables

Nature of Experiment	Item	Details	CoPb 14185	CoS 767	Co 05011	CoS 14233
Fertilizer experiments	Yield (Q/ha) under recommended dose*	i)F ₁	86.80	68.10	69.40	76.40
		ii)F ₂	89.90	73.90	75.00	76.00
	Percentage gain or loss under other doses	i)F ₂	3.57	8.52	8.07	-0.53

Note: specify fertilizer level (at i, ii, iii) and spacing (at i, ii)

F₁: Recommended F₂: + 25% NPK

*In Punjab state, the recommended dose of fertilizers are only for nitrogen i.e. 150 kg N/ ha for plant crop, 225 kg N/ ha for ratoon crop. If the soil is low in available phosphorous, apply 30 kg P per ha at planting time.

that cane yield contribution is more than sucrose content in the improvement of CCS t/ha (commercial cane sugar) (Gonzales and Galvez, 1998; Jackson, 2005; Abuellail *et al.*, 2021; Saravanan *et al.*, 2021). Clone CoPb 14185 exhibited higher per se performances for cane yield as well as sucrose %, both, when compared with standards (**Table 1 and 2**). In agronomical trials conducted during 2018-19 with two different doses of fertilizers (**Table 3**), CoPb 14185 performed better at

both fertilizer levels i.e. 86.80 t/ha at the recommended dose of fertilizers and 89.90 t/ha at 25% extra fertilizers of recommended doses. The yield differences at different fertilizer doses were less than the standards, which represent the potential of CoPb 14185 consistently excellent and stable performance at different doses of fertilizers.

All the 13 test clones along with standards were screened

Table 4(a). Reaction of CoPb 14185 (CoPb 98) to Red Rot and YLD (Artificial) in AICRP(S) trials conducted in North West Zone

S. No.	Trials/ Locations	Red Rot								Yellow Leaf Disease					
		CoPb 14185				CoS 767		Co 05011		CoS 14233		CoPb 14185	CoS 767	Co 05011	CoS 14233
		Plug method		Cotton Swab		Plug method		Plug method							
		CF08	CF09	CF08	CF09	CF08	CF08	CF09	CF08	CF09	CF08				
IVT Plant (2017-18)															
1	Lucknow	MR	MR	MR	MR	MS	S	MR	MR	MR	MR	S	-	-	R
2	Kapurthala	MR	MR	R	R	HS	HS	MR	MR	S	S	-	-	-	-
3	Uchani	MR	MR	R	R	MS	S	MR	MR	MR	R	MR	MS	MS	MR
4	Shahjahanpur	MR	MR	R	R	HS	HS	MR	MR	MR	MS	R	R	MS	MR
5	Pantnagar	-	-	-	-	MS	S	-	-	MR	MR	-	MR	-	R
6	Karnal	MR	R	R	R	S	S	-	-	S	MS	R	S	-	MR
AVT-I Plant (2018-19)															
1	Lucknow	MR	MR	R	R	MS	S	-	-	MR	MR	-	-	-	-
2	Kapurthala	MR	MR	R	R	HS	HS	MR	MR	S	MS	MR	-	-	MR
3	Uchani	MR	MR	R	R	S	MS	MR	MR	MR	MR	MR	HS	MS	MR
4	Shahjahanpur	MR	MR	R	R	HS	HS	MR	MR	MR	MS	R	R	R	R
5	Pantnagar	MR	MS	R	R	S	S	MR	MS	MR	MR	MS	MR	S	MS
6	Karnal	MR	R	R	R	S	S	-	-	MR	MS	R	S	-	R
AVT-II Plant (2019-20)															
1	Lucknow	MR	MR	R	R	MS	S	-	-	MS	MS	-	-	-	-
2	Kapurthala	MR	MR	R	R	S	S	MR	MR	S	MS	R	MS	-	MS
3	Uchani	MR	MR	R	R	S	MS	MR	MR	MR	MR	MS	S	MS	S
4	Shahjahanpur	MR	R	R	R	S	MS	MR	MR	MR	MR	MS	MS	S	MS
5	Pantnagar	MR	MR	R	R	MS	S	MR	MR	MR	MR	MR	MS	S	MR
6	Karnal	MR	MR	R	R	MS	MS	R	MR	MR	MR	MS	MS	MR	MR

against diseases (red rot, YLD, wilt, Pokkah boeng, smut) and insect-pests (early shoot borer, stalk borer, top borer) throughout the states of NWZ of India. Comparative disease scores of clones and standards presented in **Table 4a** revealed that standard CoS 767 was highly susceptible to the disease having red rot with reaction of "HS to MS" and "HS to S" against CF 08 and CF 09 pathotypes, respectively; and Co 05011 was MR to MS against pathotypes CF 08 (i.e. MR) and CF 09 (i.e. MS to MR) while CoPb 14185 was comparatively more

MR than other clones against both pathotypes (MR to CF 08 and MR to R to CF 09 pathotypes). A range of tolerant or susceptibility behaviour of clones is always being reported since long back because of environmental factors in the disease development (Ali *et al.*, 2007; Kaur *et al.*, 2016). Similarly, CoPb 14185 performed "MS to R" against YLD (**Table 4a**), "S to R" against wilt (**Table 4b**) and "MS to R" against smut (**Table 4b**) diseases. So, the disease reactions of CoPb 14185 against most of the pathogens were observed R to MR

Table 4(b). Artificial incidence of smut and wilt diseases on CoPb 14185 (CoPb 98) in AICRP(S) trials conducted in North West Zone of India

S. No.	Item/ Locations	Smut Disease				Wilt Disease			
		CoPb 14185	CoS 767	Co 05011	CoS 14233	CoPb 14185	CoS 767	Co 05011	CoS 14233
IVT Plant (2017-18)									
1	Lucknow	MR	-	R	MS	S	-	S	R
2	Kapurthala	MR	S	MR	MR	R	-	-	R
3	Shahjahanpur	MR	R	R	R	-	-	-	-
4	Pantnagar	-	MS	-	HS	-	-	-	-
AVT I Plant (2018-19)									
1	Lucknow	MS	R	-	S	S	-	-	S
2	Kapurthala	MR	S	MR	MR	MR	-	-	MR
3	Shahjahanpur	MR	R	R	MR	-	-	-	-
4	Pantnagar	R	S	R	R	-	-	-	-
AVT II Plant (2019-20)									
1	Lucknow	MR	R	-	S	S	-	-	S
2	Kapurthala	MR	-	MR	MR	MR	-	-	MR
3	Shahjahanpur	R	MR	MS	MS	-	-	-	-
4	Pantnagar	MS	R	MR	MR	-	-	-	-

Table 5. Reaction to insect pests

S. No. Trials/ Locations	Early shoot borer (Natural)				Stalk borer (Natural)				Top borer (Natural)				
	CoPb 14185	CoS 767	Co 05011	CoS 14234	CoPb 14185	CoS 767	Co 05011	CoS 14234	CoPb 14185	CoS 767	Co 05011	CoS 14234	
IVT Plant (2017-18)													
1	Kapurthala	LS	LS	LS	MS	LS	LS	LS	LS	LS	MS	LS	MS
2	Uchani	LS	LS	LS	LS	MS	LS	MS	LS	HS	MS	LS	MS
AVT-I Plant (2018-19)													
1	Karnal	LS	-	LS	LS	MS	-	HS	MS	LS	-	LS	LS
2	Lucknow	-	-	-	-	MS	-	-	MS	MS	-	-	MS
3	Shahjahanpur	LS	MS	LS	LS	MS	MS	MS	MS	LS	LS	LS	LS
AVT-II Plant (2019-20)													
1	Karnal	LS (LS)	-	LS (LS)	LS (LS)	MS (LS)	-	LS (LS)	LS (LS)	LS (LS)	-	LS (LS)	LS (LS)
2	Lucknow	-	-	-	-	HS	HS	HS	HS	HS	HS	LS	HS
3	Shahjahanpur	LS (LS)	LS (LS)	LS (LS)	LS (LS)	LS (LS)	LS (LS)	LS (LS)	LS (LS)	LS (LS)	LS (LS)	LS (LS)	LS (LS)

* Highest grade is taken out of 3rd and 4th brood.

(Anonymous, 2018; 2019; 2020). CoPb 14185 had better tolerance to borer complex (early shoot borer, top borer and stalk borer) in comparison with standards and other test clones over years and locations (Table 5). Variable response of the test clones to borer complexes in sugarcane has been well documented (Radadia and Shinde, 2013; Anonymous, 2018; 2019; 2020). An additional advantage of this clone is its tolerance to frost as well as lodging. Clone CoPb 14185 has tall, medium thick, cylindrical white canes with distinguishable morphological features. The sugar industry and sugarcane farmers of NWZ are looking for new varieties, which will improve

cane yield and sugar recovery in this region. This clone is a good agro-industrial friendly variety. Keeping in view the unique diverse features (Table 6 & Fig.2), it has been recommended by CVRC (Central Variety Release Committee) for release as a midlate maturing variety for NWZ of India. This will be expected to improve the sugar recovery and cane productivity of a nation.

Based on per cent improvement over the best standard for CCS yield, cane yield and sucrose per cent, three clones viz., CoPb 14185, CoS 14233 and CoLk 14204 qualified in the zone while CoPb 14185 was the top



Field view of CoPb 14185



Single clump of
CoPb 14185

Single Bud of CoPb
14185

Internodal view of
CoPb 14185

Fig. 2. Close view of single clump, single bud and internode of CoPb 14185 (CoPb 98)

Table 6. Distinguishing morphological characters (DUS Characters) of CoPb 14185 (CoPb 98)

S. No.	Traits	Description	S. No.	Traits	Description
1	Stalk (Cane) length	~ 211.00 cm	24	Bud shape	Pentagonal
2	Habit	Erect	25	Bud hairs distribution	Absent
3	Tillers	Medium\$	26	Bud cushion	Absent
4	-wax band	Present	27	Bud groove	Indicative
5	-exposed color	Yellow green	28	Bud extension	Touching the ring
6	-unexposed color	Green yellow	29	Bud gerpore	Sub-apical
7	-shape	Cylindrical	30	-adherence	Medium
8	-cross section	Round	31	Leaf sheath -color	Green yellow
9	-diameter (cm)	3.00	32	-waxiness	Medium
10	-length (cm)	13.02	33	-spines	Absent
11	-waxiness	Present	34	Ligule shape	Deltoid
12	-growth cracks	Absent	35	Auricle	Incipient
13	-corky patches	Absent	36	Dewlap color	Purple
14	-ivory marks	Present	37	Leaf carriage	Erect
15	-alignment	Regular	38	Lamina length (cm)	159.4
16	Node swelling	Absent	39	Lamina width (cm)	4.96
17	Root zone color	Yellow*	40	Lamina color	Green
18	Root zone width	6.60 mm	41	Pithiness	Low
19	Growth ring color	Yellow	42	HR Brix at harvest	~ 20.80 %
20	Growth ring prominence	Medium	43	Sucrose at harvest	~ 18.40 %
21	Root eye rows	Two	44	Flowering	No
22	Root eye alignment	Irregular	45	Any other trait(s)	-
23	Bud size	Medium (7.6)			

\$(5-7 tillers per clump), *(Exposed & Unexposed),

performer clone with 13.81, 11.46 and 1.70 per cent improvement, respectively (Anonymous, 2019). During 2019-20, two qualified clones viz., CoPb 14185 and CoS 14233 recorded 12.75 and 11.96 per cent improvement for cane yield and were numerically superior for sucrose %). Based on agronomical trials, CoPb 14185 was observed to have stable and higher cane yield and sucrose per cent than other clones at different levels of fertilizers. Clone CoPb 14185 performed resistance to moderately resistance reactions against diseases and insect-pests as showing more tolerant than other test clones and standards (Anonymous, 2020).

REFERENCES

- Abuellail, F., El-Taib, A.B.A. and Hefny, Y.A.M. 2021. Stability analysis and performance of promising sugarcane varieties for yield and quality traits. *Electronic Journal of Plant Breeding*, **12(3)**: 623-636. [Cross Ref]
- Ali, A., Naz, S., Alam, S. and Iqbal, J. 2007. *In vitro* induced mutation for screening of red rot (*Colletotrichum falcatum*) resistance in sugarcane (*Saccharum officinarum*). *Pak. J. Bot.* **39**: 1979- 94.
- Anna Durai, A., Premachandran, M.N., Govindaraj, P., Malathi, P. and Viswanathan, R. 2015. Variability in breeding pool of sugarcane (*Saccharum spp.*) for yield, quality and resistance to different biotic and abiotic stress factors. *Sugar Tech*, **17**: 107-115. [Cross Ref]
- Anonymous, 2017a. Project Coordinator's Report 2016-17, All India Coordinated Research Project on Sugarcane, ICAR-IISR, Lucknow, India.
- Anonymous, 2017b. Technical programme: Plant Pathology. All India Coordinated Research Project on Sugarcane, IISR, Lucknow.
- Anonymous, 2018. Project Coordinator's Report 2017-18, All India Coordinated Research Project on Sugarcane, ICAR-IISR, Lucknow, India.
- Anonymous, 2019. Project Coordinator's Report 2018-19, All India Coordinated Research Project on Sugarcane, ICAR-IISR, Lucknow, India.
- Anonymous, 2020. Project Coordinator's Report 2019-20, All India Coordinated Research Project on Sugarcane, ICAR-IISR, Lucknow, India.

- Anonymous, 2020a. Package of Practices for *kharif* crops. Punjab Agricultural University, Ludhiana, Pp. 50-66.
- Charumathi, M. and Naidu, N.V. 2015. Studies on the performance of sugarcane varietal impact on cane yield and sugar recovery in tropical zone of India. *Paripex - Indian J. Res.*, **4(12)**: 142-145.
- Cox, M.C., Hogarth, D.M. and Hansen, P.B. 1994. Breeding and selection for high early season sugar content in a sugarcane (*Saccharum* spp. hybrids) improvement program. *Aust. J. Agric. Res.*, **45(7)**: 1569-75. [\[Cross Ref\]](#)
- FAO, 2019. Food Outlook - Biannual Report on Global Food Markets. November. 2019. Rome.
- Gonzales, A.R. and Galvez, R.G. 1998. Early maturing varieties of high sugar content. Sugar Cane Abstracts, *Cane breeding and varieties*, **5**: 23.
- Jackson, A.A. 2005. Breeding for improved sugar content in sugarcane. *Field Crops Res.*, **92**: 277-90. [\[Cross Ref\]](#)
- Kaur, M., Thind, K. S., Sanghera, G. S., Kumar, R. and Kashyap, L. 2016. Gamma rays induced variability for economic traits, quality and red rot resistance in sugarcane (*Saccharum* spp.). *Int. J. Environ. Sci. Technol.*, **5(2)**: 355-65.
- Meade, G. P. and Chen, J. C. P. 1971. Cane sugar hand book. 10th edition, John Wiley and Sons. New York.
- Panse, V. G. and Sukhatme, P. V. 1978. Statistical methods for Agricultural workers. ICAR Publications, New Delhi, Pp. 347.
- Radadia, G.G. and Shinde, C.U. 2013. Research methodology for recording observations of sugarcane pests. All India Coordinated Research Project on Sugarcane (Indian Council of Agricultural Research) Pp: 1-8.
- Saravanan, N. A., Sudhagar, R., Thirumurugan, A. and Kanchanarani, R. 2021. CoG 6 - A high yielding and quality sugarcane variety. *Electronic Journal of Plant Breeding*, **12(3)**: 606-611. [\[Cross Ref\]](#)
- Singh, V. and Singh, K. 2021. Identifying potential sugarcane families for cane yield and juice quality traits in early selection stages. *Agric. Res. J.*, **58 (3)**: 390-398. [\[Cross Ref\]](#)
- Snedecor, G.W. and Cochran, W.G. 1967. Statistical Methods. 6th edition. Oxford and IBL Publication Co Calcutta. Pp: 593.
- Srinivasan, K. and Bhatt, N. R. 1961. Red rot of sugarcane criteria for grading resistance. *J. Indian Bot. Soc.*, **11**: 566-577.
- Sugar Statistics, 2020. Cooperative Sugar, National Federation of Co-operative Sugar Factories Ltd, January 2020, 51(5).